

5000L Water Tank

AS/NZS 1546.1:2008
Licence No: 1486

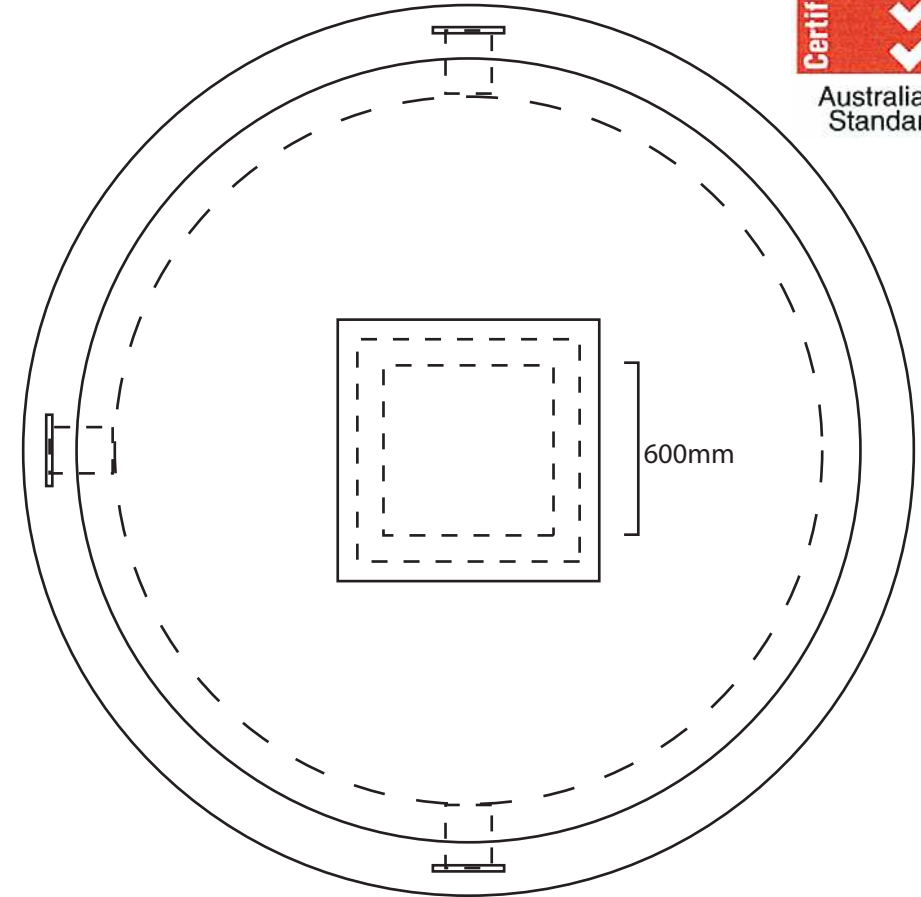
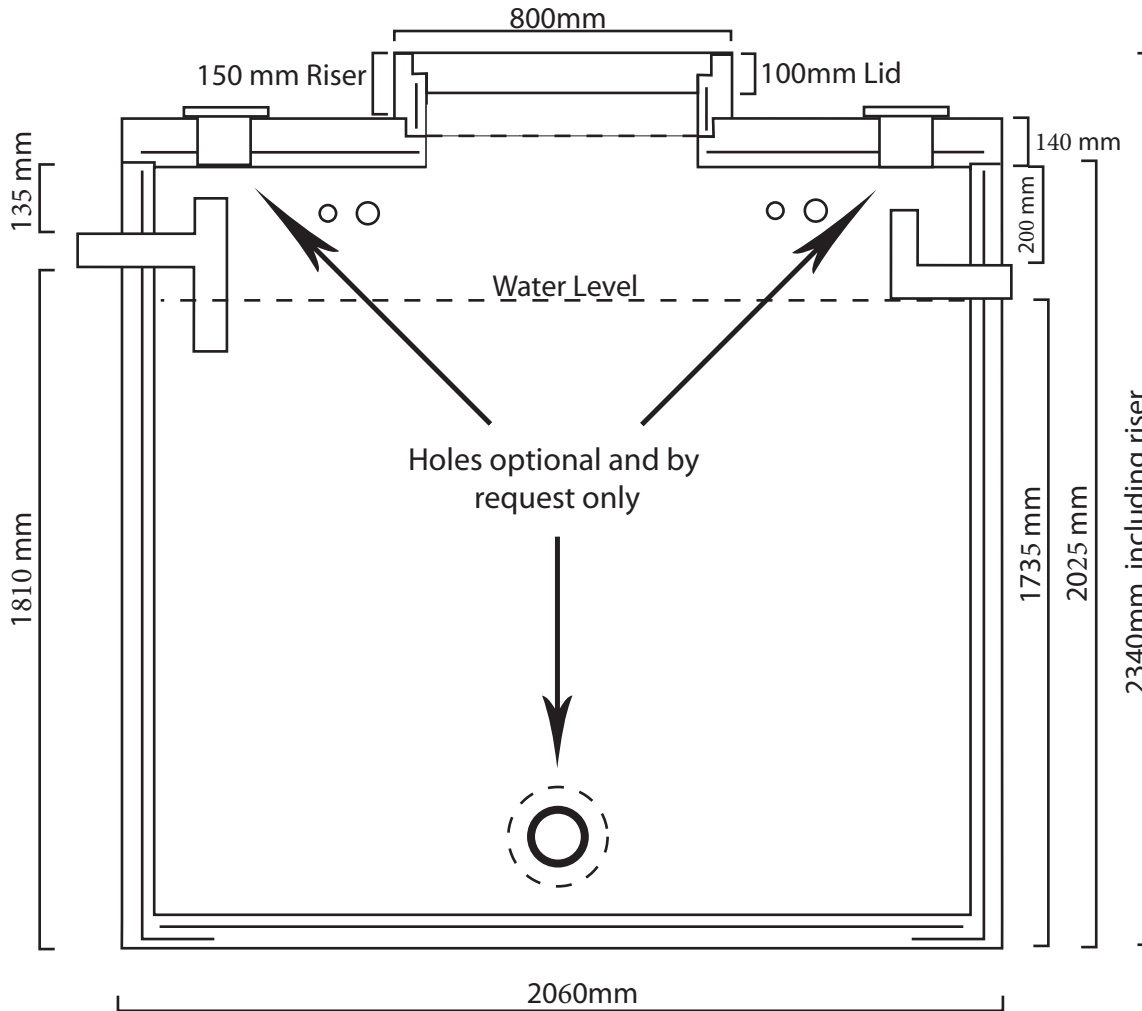

Installation instructions: Hole excavation must be 2.4m square. Depth to 2200mm + Riser height. Base must be covered in 50mm of sand or equivalent.
Risers available in 150mm, 300mm, 450mm & 600mm. (Diagram shows tank with 150mm Riser)
Inspection holes in lid and joining hole in tank are optional and manufactured only by request.