



Health

Certificate of Accreditation

Sewage Management Facility

Septic Tanks & Collection Wells

This Certificate of Accreditation is issued by the Secretary of the NSW Ministry of Health pursuant to Clause 41(1) of the Local Government (General) Regulation 2005.

Manufacturer: Mid West Concrete Pty Ltd

Of: 84 Marshalls Lane, Blaney, NSW, 2799

The Mid West Concrete Pty Ltd concrete Septic Tanks and Collection Wells as described in the following Schedule have been accredited as sewage management facilities for use in single domestic premises in NSW.

*Director, Environmental Health
for Secretary (delegation PH335)*

Issued: 1 November 2018

Certificate No: STCW016

Expires: 31 December 2020



Health

Accreditation Schedule

*The Certificate of Accreditation applies to the following
Septic Tanks and Collection Wells*

Model	Description	Size
Septic Tank	Vertical axis type, cylindrical precast concrete with steel reinforcing mesh with lid, access cover, inlet and outlet fittings.	2050 L (without partition)
	Burial depth of the tank lid is restricted to 0-500 mm	2300 L 3400 L 4000 L (with partition)
Collection Well	Vertical axis type, cylindrical precast Concrete with steel reinforcing mesh. Certification applies only to the construction of the tank, lid and access cover. It does not include internal fittings or partitions. Burial depth of the tank lid is restricted to 0-500 mm	2050 L 2500 L 3600 L 4000 L 5000 L

On Site Domestic Waste Water Treatment Units - Septic Tanks

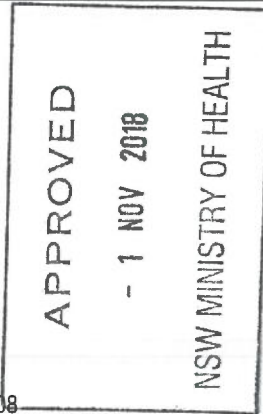

Model	A	B	C	D	E
MWC 2	754	570	900	1545	460
MWC 3	858	683	1160	1705	460
MWC 5	1090	885	1740	1900	460
MWC 7	1240	1005	1740	2135	310
WT5000				2200 + RISER	

AS/NZS 1546.1:2008
Licence No: 1486

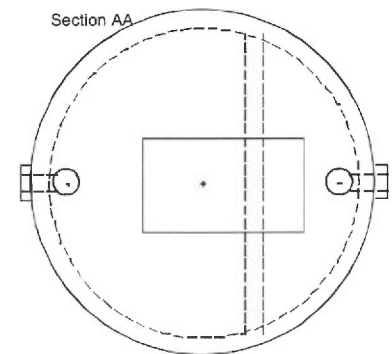
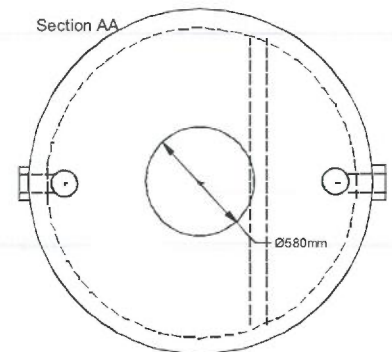
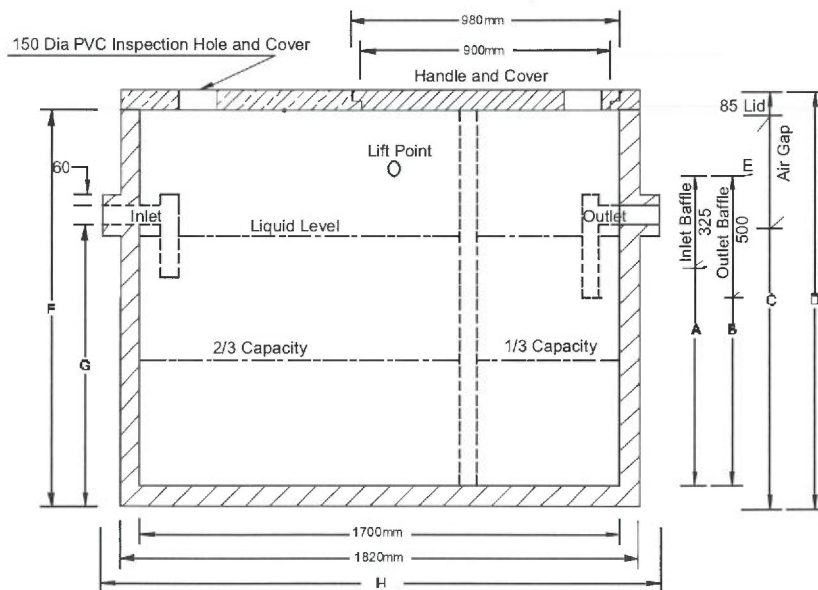

Model	Type	Capacity	F	G	H
MWC2	Collection Well	2050lt	1460mm	1060mm	2m
MWC3	Septic Tank	2300lt	1620mm	1220mm	2m
MWC4	Collection Well	2500lt	1620mm	1200mm	2m
MWC5	Septic Tank	3400lt	1815mm	1410mm	2.2m
MWC6	Collection Well	3600lt	1815mm	1410mm	2.2m
MWC7	Septic Tank	4000lt	2050mm	1650mm	2.4m
MWC8	Collection Well	4000lt	2050mm	1650mm	2.4m
WT5000	Collection Well	5000lt	2200mm + Riser	1790mm	2.4m

Installation Instructions: Hole excavation must be; 2m square for tanks up to 2300lt. 2.2m square for tanks up to 3400lt. 2.4m for 4000lt and 5000lt tanks. Depth to F. Base must be covered with 50 mm of sand or equivalent. For collection wells blank off outlet.